

Pressure Relief



Pressure Relief and Sequence Valves

CG2V-6/8, 10 Series; CG5V-6/8, 20 Series

Typical Section

CG2V-6*W-10 relief valve

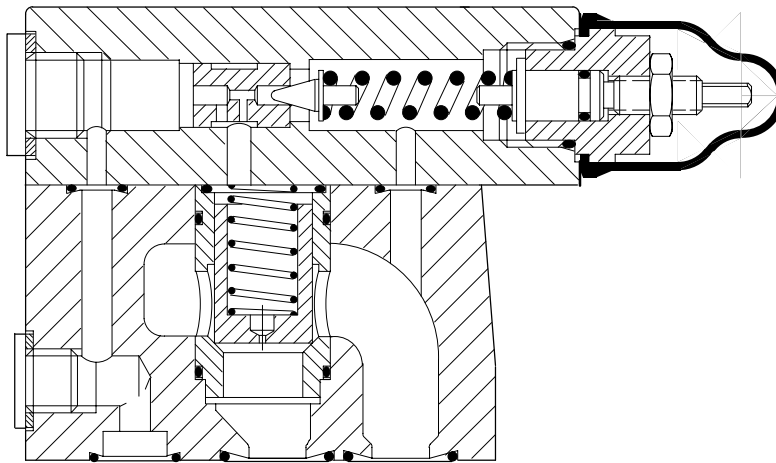

Features and Benefits

- Close matching to application requirements from choice of four adjustment control ranges covering 3 to 350 bar (44 to 5000 psi).
- Electrical on/off load from solenoid controlled models.
- Remote parallel control by other pilot valves connected to "vent" port.
- High machine productivity resulting from full system flow being available for work output until system pressure is very close to valve setting.
- Pressure override optimized without detriment to other performance parameters.
- Excellent repeatability and stable performance from cartridge-type design of mainstage parts.
- Low off-load power wastage.
- International mounting interfaces.
- Low installed cost and space requirement from high power/size ratios (more than double that of many conventional designs).

Basic Characteristics

Maximum pressure 350 bar
(5000 psi)
Maximum flow 400 L/min
(106 USgpm)
Mounting face to ISO 6264:
CG*V-6 valves AR-06-2-A
CG*V-8 valves AS-08-2-A

- CG2V-***, 10 series: relief/sequence valve with integral manual adjustment of pressure setting.
- CG5V-***, 20 series: relief valve with solenoid operated pilot valve for loading/unloading.

A third type, KCG-*, 10 series, with proportional pilot control valve, is described in catalog 2324.

General Description

These two-stage valves are used to limit or control pressure by directing up to the total system fluid flow to reservoir when system pressure reaches the setting of the valve. System actuators are thus protected against overload.

Each relief valve incorporates a vent port that can be connected to a separate pilot control valve to remotely control or unload system pressure.

Two types of valve are presented in this catalog:

Functional Symbols

Relief valve, manually adjusted,
CG2V-***-1* model

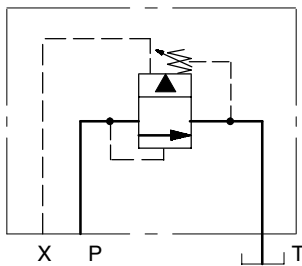

Sequence valve, manually adjusted,
CG2V-***-1-1* model▲

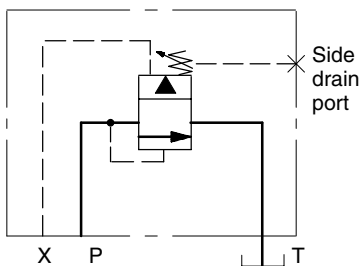

▲ If a valve with an integral, reverse free-flow check is required, use a type RCG valve, as in catalog 429.

Solenoid controlled relief valve, pilots internally drained, CG5V-***-D-2* model

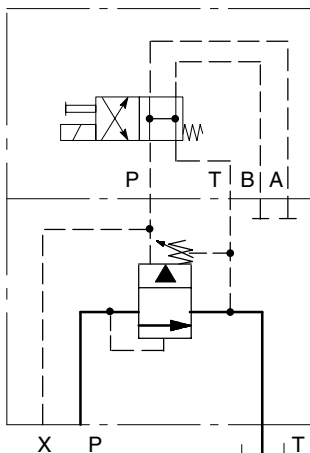

Model Codes

For Valves with Manual Adjustment Only

(F3-) CG2V-* * * (-1)-1*

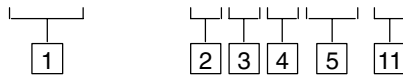

For Valves with Manual Adjustment Plus Electrical Load/Unload

(F3-) CG5V-* * * -D(-*)-(V) M- * (-L)- * 5-2***

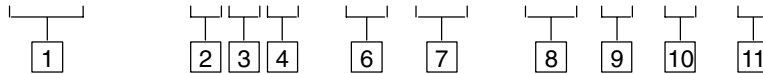

1 Fluid compatibility

Blank = Antiwear hydraulic oil (class L-HM), invert emulsion (class L-HFB) or water glycol (class L-HFC)

F3 = As above or phosphate ester (class L-HFD)

2 Mounting surface, ISO 6264

6 = AR-06-2-A

8 = AS-08-2-A

3 Pressure adjustment control range

B = 3 to 70 bar (44 to 1000 psi)

C = 3 to 140 bar (44 to 2000 psi)

F = 3 to 210 bar (44 to 3000 psi)

G = 3 to 350 bar (44 to 5000 psi)

4 Type of manual adjustment

K = Micrometer with keylock

M = Micrometer without keylock

W = Screw/locknut

5 Drain options

1 = External drain from side port:
CG2V sequence-version
(see "Functional Symbols")

Omit for CG2V relief-version and for CG5V models

6 Manual override options, CG5V only

Override in solenoid end

Blank = Plain override

H = Water-resistant override,
DC solenoid only

Z = No override

7 Solenoid energization identity, CG5V only

V = Solenoid "A" at port A end of pilot valve (energizing "A" connects P to B pilot ports): German practice.

Omit for solenoid identity "B" (energizing "B" connects P to B pilot ports): USA ANSI B93.9/NFPA standard.

8 Solenoid connection type▲, CG5V only

U = ISO 4400 (DIN 43650)◆

FW = 1/2" NPT thread conduit box

FTW= 1/2" NPT thread conduit box and terminal strip

FJ = M20 thread conduit box

FTJ = M20 thread conduit box and terminal strip

▲ Other connection types as shown in catalog 2015 (DG4V-3/3S) may be made available depending on quantities.

◆ Female connector to be supplied by user.

9 Indicator lights, CG5V only

Option for solenoid connection types FTW and FTJ, see position 8

L = Lights fitted

Omit if lights not required

For U-code solenoid, use plug with integral light, see "Electrical Plugs and Connectors"

10 Coil rating, CG5V only

See "Operating Data" for further information

A = 110V AC 50 Hz

B■ = 110V AC 50 Hz/120V AC 60 Hz

C = 220V AC 50 Hz

D■ = 220V AC 50 Hz/240V AC 60 Hz

G = 12V DC

H = 24V DC

■ For 60 Hz or dual frequency.

11 Design number

10 series for CG2V valves

20 series for CG5V valves

Subject to change. Installation dimensions unaltered for design numbers 10-19 and 20-29 inclusive.

Operating Data

Data is typical with oil at 22 cSt (106 SUS) and at 50°C (122°F)

Maximum pressures: Ports P and X Port T▲: CG2V valves, 10 series CG5V valves, 20 series ▲ For relief valves this is normally connected directly to reservoir because back pressure here adds to the effective setting of the valve.	350 bar (5000 psi) 350 bar (5000 psi) 100 bar (1500 psi) CG5V, 20 series valves are designed to satisfy the needs of most applications. Consult your Vickers representative about an alternative model if: a) Valves are required to remain pressurized for long periods without frequent switching, and/or b) Back pressure on port T is required to rise above 100 bar (1500 psi).
Pressure adjustment ranges	See model code 3
Maximum flow rates: CG*V-6 CG*V-8	200 L/min (53 USgpm) 400 L/min (106 USgpm)
Vent ▼ flow, port X, when used ▼ See "Vent Function" explanation two pages on.	3 L/min (0.8 USgpm) with valve at max. flow rate
Drain flow, CG*V valves, when manual adjuster and/or pilot valve (i.e. CG5V) are in operation: CG*V-6 CG*V-8	1,1 L/min (0.3 USgpm) 1,8 L/min (0.47 USgpm)
Response time, CG5V valves Typical time from applying signal at solenoid, with valve vented, until relief main valve closes; with minimum pressurized volume	170 ms
Hydraulic fluids and fluid temperatures	See three pages on
Temperature limits	See three pages on
Thermal stability (pressure/temperature change)	0,2 bar/°C (1.6 psi/°F)
Spare parts/service information: CG*V valves	Publication no. 40751

Electrical Data, CG5V Valves

Coil voltages	See model code 10	
Permissible voltage fluctuation: Maximum	See "Temperature Limits", two pages on	
Minimum	90% rated (see model code 10)	
Relative duty factor	Continuous; ED = 100%	
Types of protection: ISO 4400 coils with plug fitted correctly Conduit box Coil winding Lead wires (coils type "F**") Coil encapsulation	IEC144 class IP65 IEC144 class IP65 Class H Class H Class F	
Power consumption for coils listed in model code 10 :	Initial ♦ VA (RMS)	Holding VA (RMS)
AC coils:		
Single frequency coils at 50 Hz	225	39
Dual frequency coils at 50 Hz	265	49
Dual frequency coils at 60 Hz	260	48
DC coils, at rated voltage and 20°C (68°F):		
Type G, 12V DC	30W	—
Type H, 24V DC	30W	—
	♦ 1st half cycle; solenoid armature fully retracted	

Performance Data

Typical with oil at 22 cSt (106 SUS) and at 50°C (122°F)

Pressure Override When Relieving

CG2V-8 examples

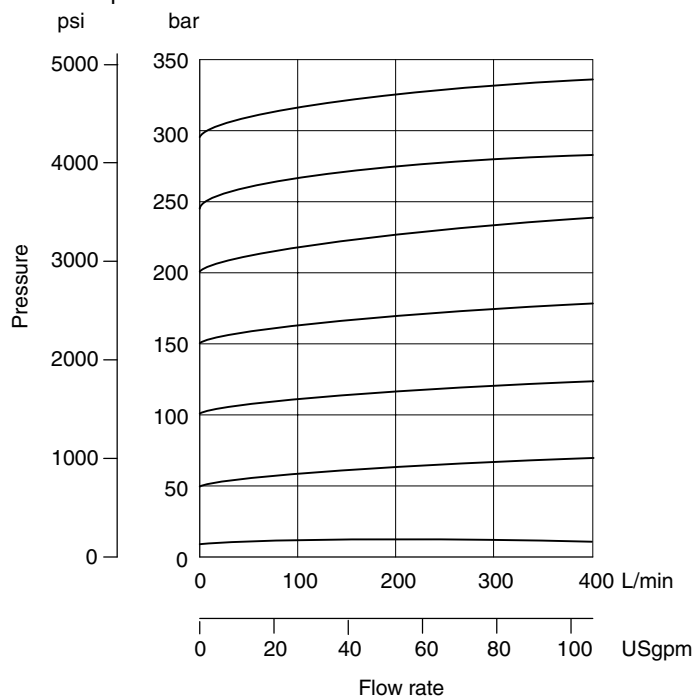

Pressure Override When Venting

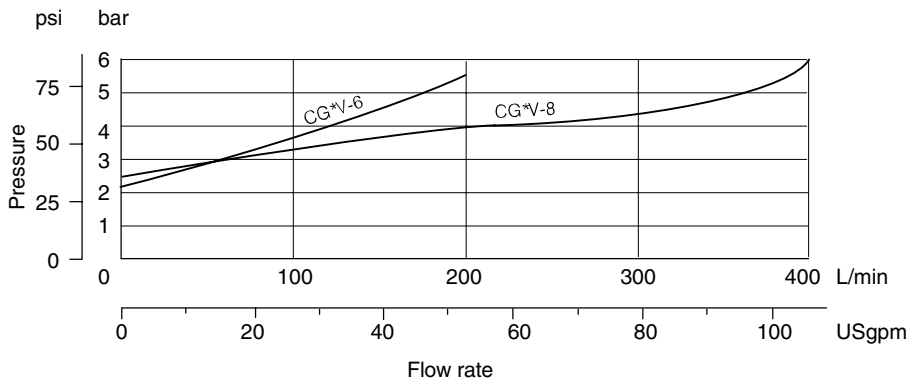

Control Data for CG2V Valves

Manual adjustment of pressure setting described in "Installation Dimensions".

Venting

System pressure can be dropped to near-zero by connecting vent port X to reservoir through a suitable pilot valve, e.g:

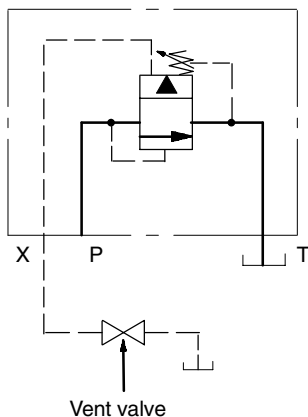

Control Data for CG5V Valves

Vent Function

The solenoid operated pilot valve is Vickers model type DG4V-3S, with spool type "0B" (ref. catalog 2015). When the solenoid is de-energized, the CG5V relief valve is unloaded by venting the pilot drain to port T. Note that any back pressure at port T is additive to the minimum possible unloaded pressure, and is also additive to the on-load pressure setting.

When the solenoid is energized the pilot flow is blocked to bring the relief valve on load. For this function port X would normally be blocked (e.g. no connection from the mounting face). Further remote control pressure settings are possible by connecting port X to suitable pilot relief valves via other DG4V-3S type directional control valves.

Hydraulic Remote Control

Remote adjustment of pressure setting can be made by a pilot relief valve, substituted for the vent valve in the diagram. Suitable pilot relief valves are described in catalogs 411 (type C-175 valves) and 409 (type CGR-02 valves).

Hydraulic Fluids

All valves can be used with:

Antiwear hydraulic oils (class L-HM)

Invert emulsions (class L-HFB)

Water glycol (class L-HFC)

Phosphate ester (class L-HFD), adding "F3-" prefix at model code [1](#).

The extreme viscosity range is from 500 to 13 cSt (2270 to 70 SUS) but the recommended range is 54 to 13 cSt (245 to 70 SUS).

For further information about fluids see "Technical Information" leaflet 920.

Temperature Limits

Minimum ambient: -20°C (-4°F)

Maximum ambient:

For CG2V valves: 70°C (158°F)

For CG5V valves with coils listed in model code [10](#) and at 110% of rated voltage:

Coil type and frequency	Max. ambient temperature
Dual frequency coils	
at 50 Hz	65°C (149°F)
at 60 Hz	65°C (149°F)
Single frequency (50 Hz) coils	
at 50 Hz	65°C (149°F)
DC coils	70°C (158°F)

Fluid temperatures (all models)

	Petroleum oil	Water-containing
Min.	-20°C (-4°F)	+10°C (+50°F)
Max.*	+70°C (+158°F)	+54°C (+129°F)

* To obtain optimum service life from both fluid and hydraulic system, 65°C (150°F) normally is the maximum temperature except for water-containing fluids.

For synthetic fluids consult fluid manufacturer or Vickers representative where limits are outside those of petroleum oil.

Whatever the actual temperature range, ensure that viscosities stay within the limits specified in the "Hydraulic Fluids" section.

Contamination Control Requirements

Recommendations on contamination control methods and the selection of products to control fluid condition are included in Vickers publication 9132 or 561, "Vickers Guide to Systemic Contamination Control". The book also includes information on the Vickers concept of "ProActive Maintenance".

The following recommendations are based on ISO cleanliness levels at 2 µm, 5 µm and 15 µm. For products in this catalog the recommended levels are:

Up to 210 bar (3050 psi) 19/17/14

Above 210 bar (3050 psi) 19/17/14

Installation Dimensions in mm (inches)

CG2V Models

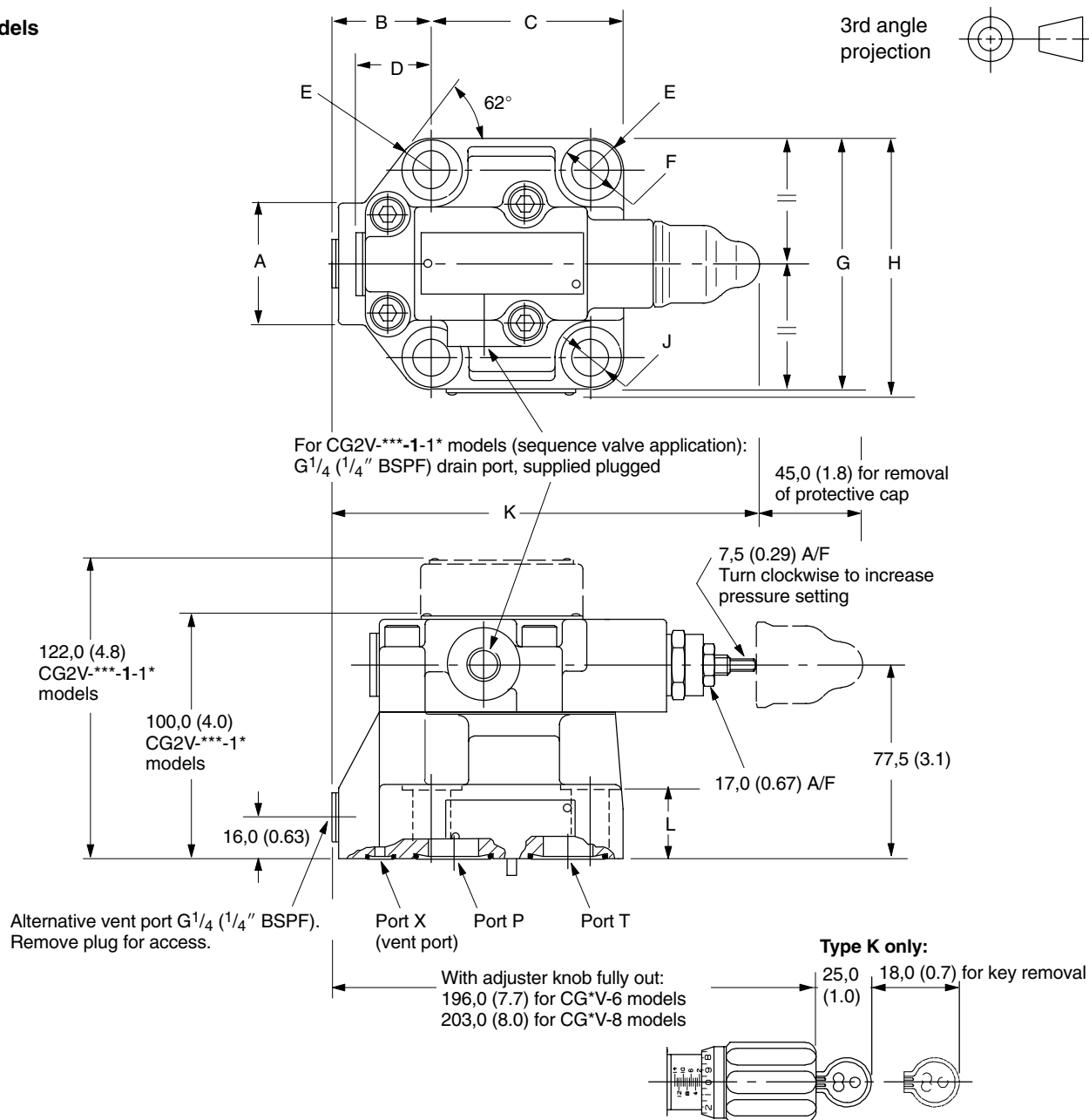

Model	A	B	C	D	E rad.	Ø F (dia)	G
CG*V-6	58,0 (2.3)	35,0 (1.4)	68,0 (2.7)	35,0 (1.4)	12,0 (0.5)	20,0 (0.78)	79,0 (3.1)
CG*V-8	42,0 (1.7)	39,0 (1.54)	83,0 (3.3)	30,0 (1.2)	16,0 (0.63)	26,0 (1.02)	103,0 (4.1)

Model	H	Ø J (dia)	K	L	M (AC coils)	M (DC coils)
CG*V-6	82,0 (3.23)	13,5 (0.53)	176,0 (7.0)	20,0 (0.78)	160,0 (6.3)	170,0 (6.7)
CG*V-8	106,0 (4.2)	17,0 (0.7)	183,0 (7.2)	25,0 (1.0)	169,0 (6.65)	179,0 (7.1)

Micrometer Adjustment Options: "K" or "M" in Model Code 4

"K" Feature

To adjust pressure setting, insert key and turn clockwise. Turn micrometer knob clockwise to increase pressure setting; counter-clockwise to decrease setting. When the key is removed the knob can spin freely without affecting the pressure setting.

CG5V Models

With Type "U" Coil Connection

("U" at model code **8**)

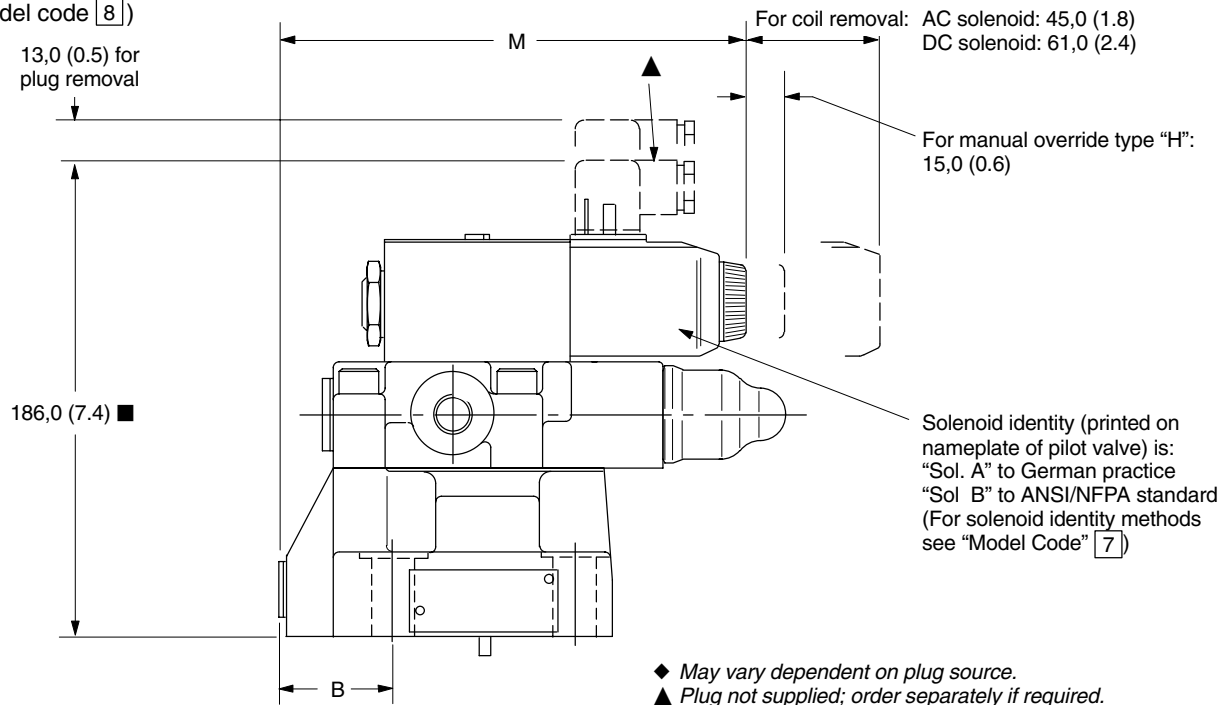

For dimensions "B" and "M", see previous page.

◆ May vary dependent on plug source.

▲ Plug not supplied; order separately if required.

For available plug types see section "Electrical Plugs and Connectors".

With Type "F" Coil Connection

("F(T)J" or "F(T)W" at model code **8**)

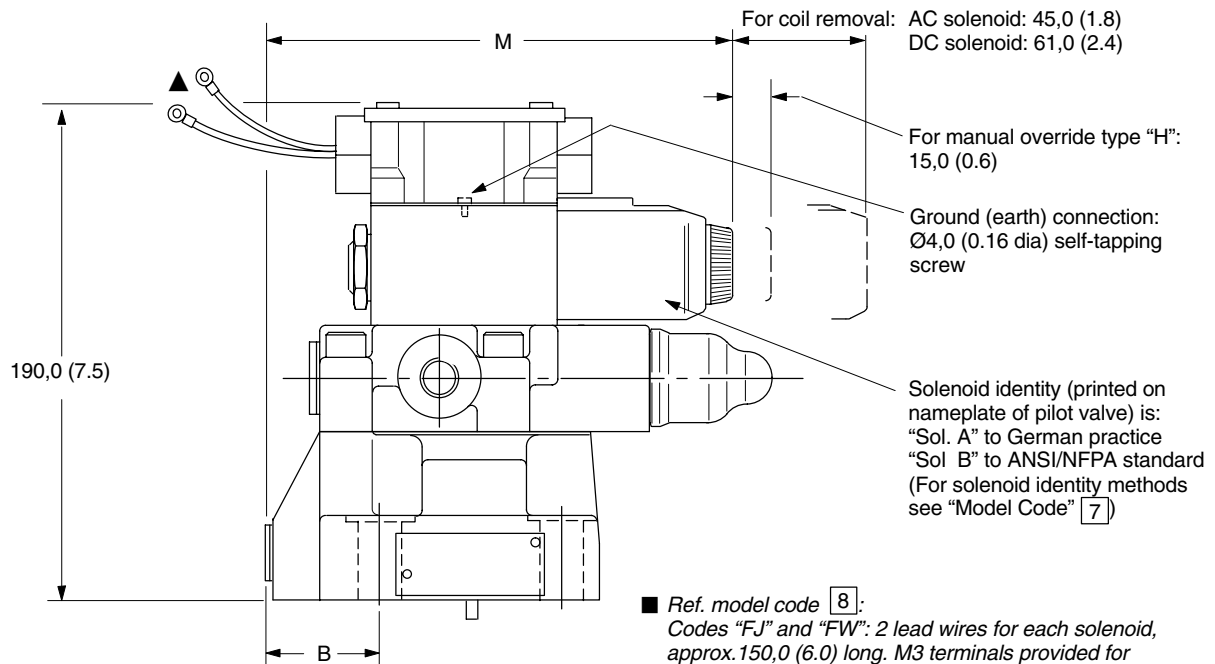

◆ Ref. model code **8**:

Codes "FJ" and "FW": 2 lead wires for each solenoid, approx. 150,0 (6.0) long. M3 terminals provided for customer connection.

Codes "FTJ" and "FTW": lead wires connected into terminal strip suitable for M3 terminals on customer connection.

For dimensions "B" and "M", see previous page.

Views on Bottom Faces of Valves

See also "Mounting Surfaces".

All O-seals supplied.

CG*V-6

CG*V-8

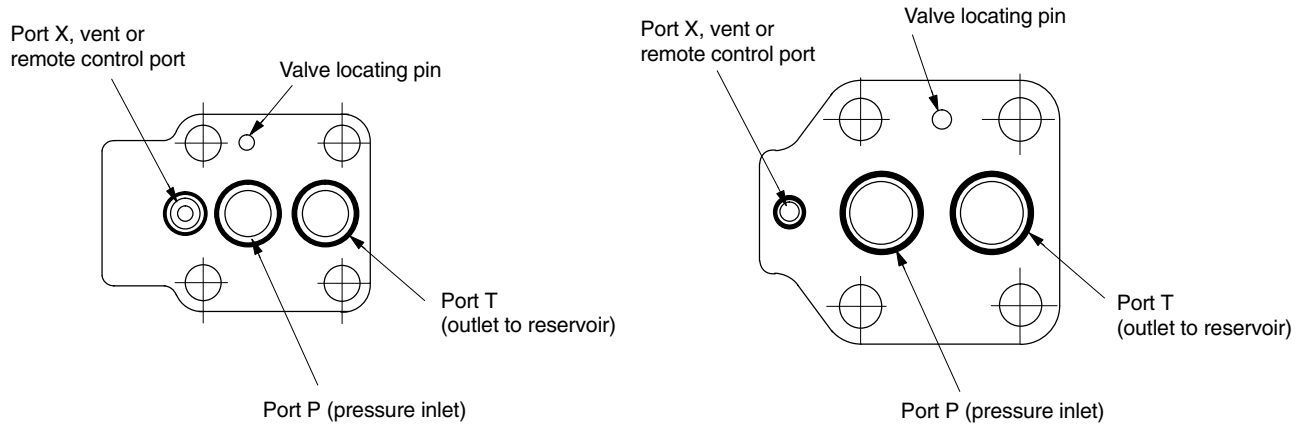

CGVM-6-10-R Subplate

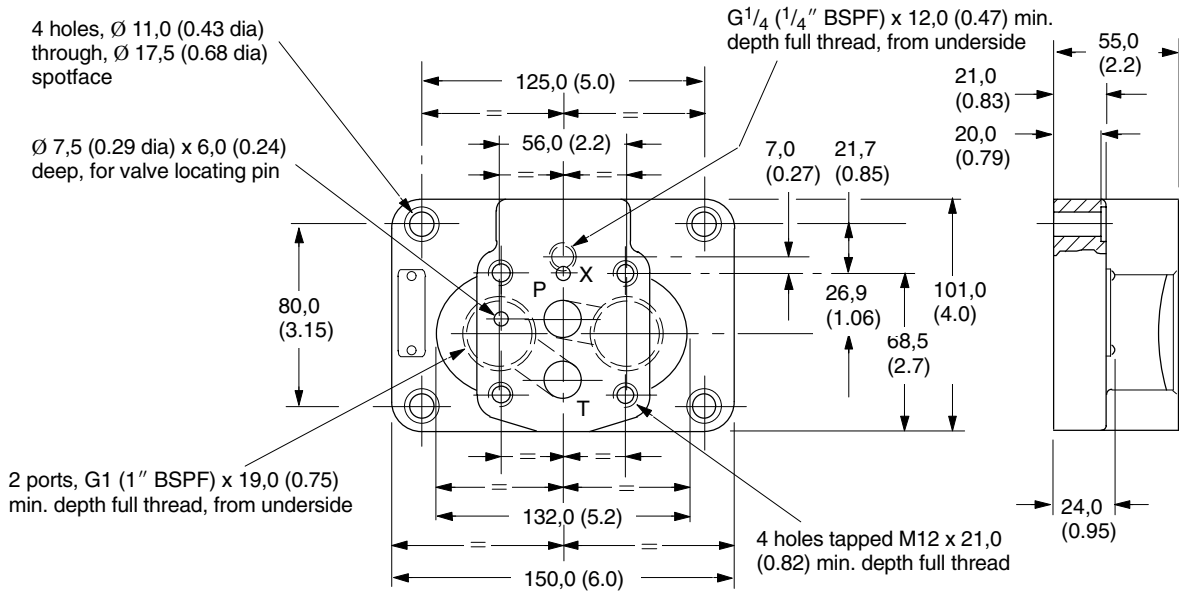

Mounting Surfaces, ISO 6264

AR-06-2-A

AS-08-2-A

When a subplate is not used a raised pad must be provided for mounting. The pad must be flat within 0,001 mm/100 mm (0.0001"/10") and smooth within 0,8 µm (32 µin). Dimensional tolerances are ±0,2 mm (0.008") except where indicated.

Port functions

P = Pressure inlet

T = Outlet to reservoir

X = Vent, or remote pilot control port

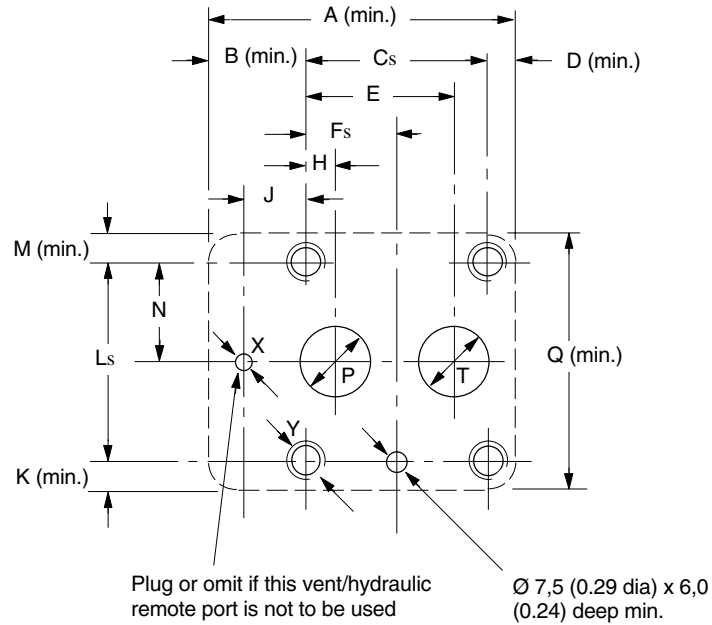

Size	A	B	C	D	E	F	H	J	K	L
AR-06	80 (3.2)	13,1 (0.5)	53,8 (2.12)	13,1 (0.5)	47,5♦ (1.87)	22,1 (0.87)	22,1♦ (0.87)	0 (0)	13,1 (0.5)	53,8 (2.12)
AS-08	118 (4.7)	35,0 (1.4)	66,7 (2.63)	16,3 (0.7)	55,6 (2.19)	33,4 (1.35)	11,1 (0.44)	23,8 (0.94)	16,0 (0.63)	70,0 (2.76)

Size	M	N	Ø P (dia)	Q	Ø T (dia)	Ø X (dia)	Y thread x min. full thread depth
AR-06	13,1 (0.5)	26,9 (1.06)	14,7 (0.58)	80 (3.2)	14,7 (0.58)	4,8 (0.19)	M12 x 21 (⁷ / ₁₆ " UNF x 0.83) ▼
AS-08	16,0 (0.63)	35,0 (1.38)	23,4 (0.92)	102 (4.0)	23,4 (0.92)	6,3 (0.25)	M16 x 30 (⁵ / ₈ " UNF x 1.2) ▼

▲ Tolerance on bolt and pin locations ± 0,1 (0.004).

♦ These ISO standard dimensions can be used, but improved flow paths to and from valve are obtained by using 48,0 (1.89) instead of 47,5 (1.87), and 22,6 (0.89) instead of 22,1 (0.87).

▼ ISO standard does not give UNC bolt sizes. These are recommended equivalents to metric sizes specified in the standard.

Installation Data

Mounting Attitude

Unrestricted.

Subplates

For CG*V-6 valves see type CGVM-6-10-R on previous page.

For CG*V-8 valves consult your Vickers representative.

Mounting Bolts/Torques

For CG*V-6 valves: bolt kit BKCG2V-6. Bolts should be torqued to 103-127 Nm (76-94 lbf ft), with threads lubricated.

For CG*V-8 valves: bolt kit BKCG2V-8. Bolts should be torqued to 257-315 Nm (190-232 lbf ft), with threads lubricated.

Mass (approx.)

CG2V-6 3,5 kg (7.7 lb)

CG2V-8 4,4 kg (9.7 lb)

CG5V-6:

With AC solenoid 5,0 kg (11 lb)

With DC solenoid 5,2 kg (11.5 lb)

CG5V-8:

AC solenoid 5,9 kg (13 lb)

DC solenoid 6,1 kg (13.5 lb)

Electrical Plugs and Connectors

Plugs for ISO 4400 (DIN 43650) Type Coil Connection

For CG5V valves with type “U” coils (model code 8)

The cable entry on these plugs can be repositioned at 90° intervals by reassembly of the contact holder relative to the plug housing. The cable entry is Pg11 for cable Ø 6-10 mm (0.24-0.4”).

Order plugs separately by part number.

Voltage	Part number	
	Gray (Sol.A)	Black (Sol.B)
Without indicator light		
–	710776	710775
With indicator light		
12- 24V	977467	977466
100-125V	977469	977468
200-240V	977471	977470

Terminal Strip and Lights

For CG5V valves with type F(T)J or F(T)W coils, see model code 8

For “FTJ” or “FTW” at model code 8

For “FTJL” or “FTWL” at model code 8 + 9

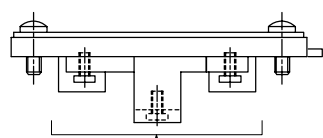

Terminal strip (part number 890345) clips to cover and can be field-fitted

Conduit box cover and nameplate complete with sealing gasket and 4 screws

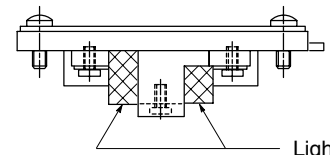

Lights

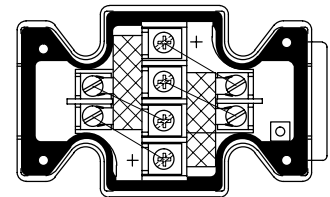
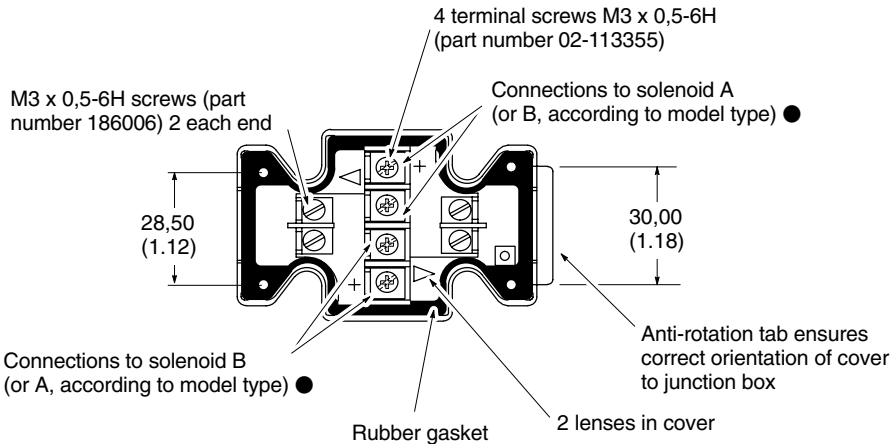

● 1. For DC coils the +ve lead(s) must be connected to the terminal(s) marked +. When using 3-wire incoming leads to double solenoid valves (i.e. common neutral) the inner pair of terminals must be linked.

2. For correct light indication of energized solenoid ensure that solenoid leads are correctly connected: light terminals are common with each outer pair of solenoid terminals according to the side with + mark.

Ordering Procedure

Valves, subplates and bolt kits should be ordered by full model code designation. Order plugs by part number.